



# CENTRIFUGAL RANGE

2CPM TWIN IMPELLER



# TWIN STAGE PUMPS



## 2CPM

### Range of performance

Flow rate: max 180 L/min  
(10.8m<sup>3</sup>/h)

Head: max 70m

### Limits of use

Suction height: max 7m

Liquid temperature: 60°C

Environmental temperature: 40°C

### Uses and installations

They are recommended for pumping clean water without abrasive particles and liquids that are chemically non aggressive for the materials of which the pump is made. The high head and adaptability to the most varied, even unusual applications make them the ideal choice in the domestic, civil and industrial field and specifically for increase pressure in the mains for fire-fighting sets. The pump must be installed under a vented cover and protected against exposure to rain or water spray.



### Construction Characteristics

Pump Body: Cast Iron  
 Impellers: Brass / Brass  
 Motor Shaft: Stainless Steel 304  
 Mechanical Seal: Ceramic-graphite  
 Electric Motor: Single-phase 230V - 50Hz with capacitor and thermal overload protector.  
 CP: three-phase 380/400v -50Hz  
 Insulation: Class F  
 Protection: IP 44

### Diagram

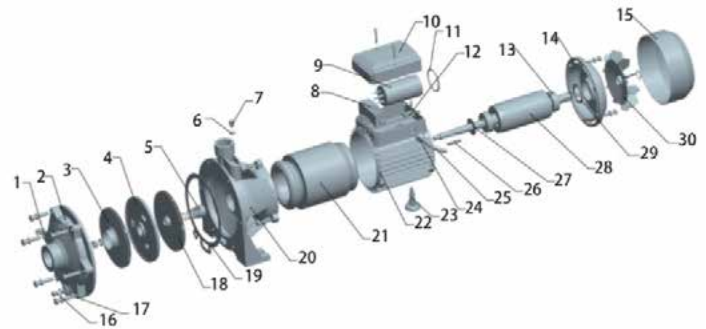

### Diagram

No.	Description	No.	Description	No.	Description	No.	Description
1	Air vent screw	9	Capacitor	17	O-Ring	25	Cable
2	Pump body	10	Capacitor cover	18	Impeller	26	Key
3	Impeller	11	O-Ring	19	Gasket	27	Water proof ring
4	Pump Cover	12	Cable fixer	20	Coupling	28	Rotor
5	Mechanical Seal	13	Bearing	21	Stator	29	Wave spring
6	O-Ring	14	End Cover	22	Motor bracket	30	Fan
7	Air vent screw	15	Fan Cover	23	Foot		
8	Terminal Board	16	Water vent screw	24	Cable protector		

# PERFORMANCE CURVE



## Hydraulic Performance Curve

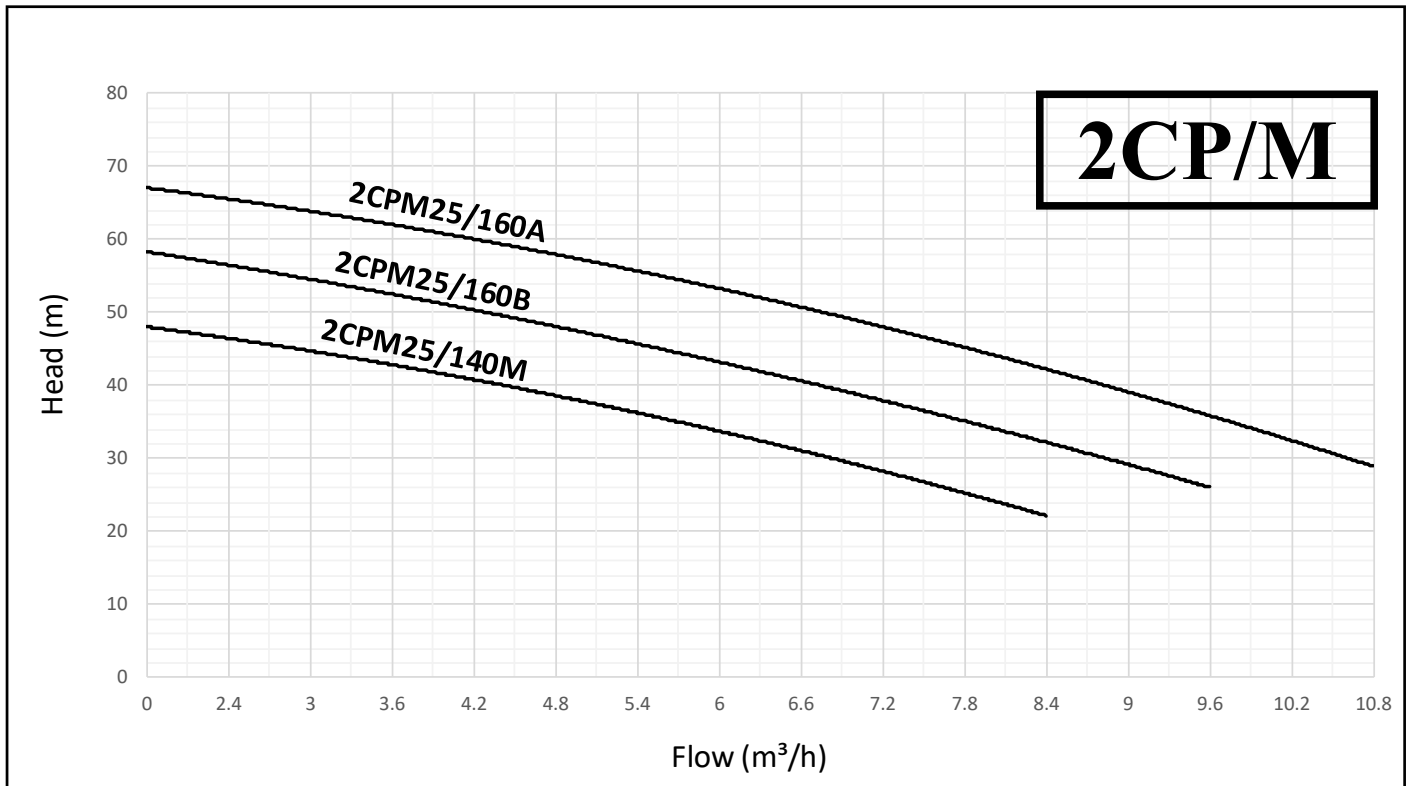

## Technical Data

NO	MODE	POWER		Q (m³/h)		0	2.4	3	4.2	4.8	6	6.6	8.4	9.6	10.8	
	1ph / 3ph	kW	HP	Q (l/min)		0	40	50	70	80	100	110	140	160	180	
1	2CP/M25/140M	1.1	1.5	H (m)	47	46.7	45.4	41.7	38	34	30	23				
2	2CP/M25/160B	1.5	2		58	56.4	54.3	51.4	48	44	39	33	26			
3	2CP/M25/160A	2.2	3		68	66	63	60	57	54	50	43.5	36.2	28		

## Dimension

No	Model	Freq.	Suct. Max	Size	Start-up Amps (1ph)	Running Amps (1ph)	Dimension	N/W
	1ph / 3ph	Hz	m	inch	A	A	L x W x H mm	kg
1	2CP/M25/140M	50	7	1.5" x 1"	28	9	410x242x280	20.5
2	2CP/M25/160B	50	7	1.5" x 1"	30.5	9.7	435x250x305	25
3	2CP/M25/160A	50	7	1.5" x 1"	35	13.3	518x278x345	27